

72031ED10X

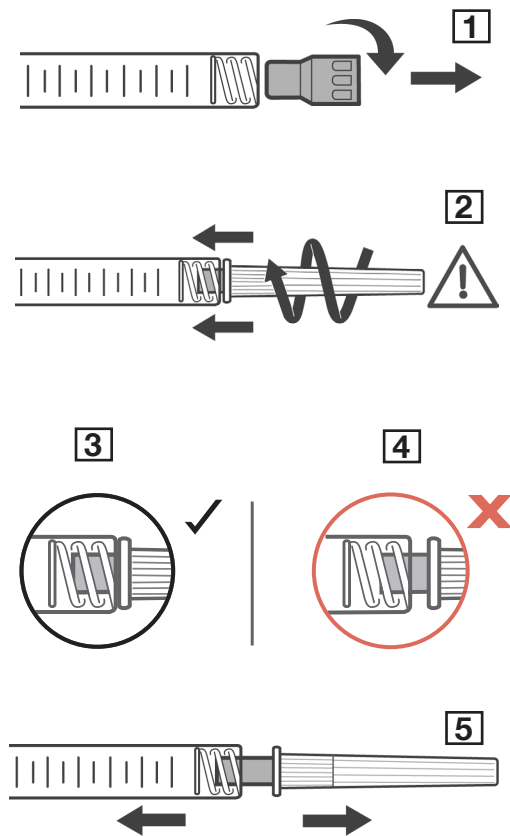

**Manufacturer:** **ALLERGAN**  
Route de Promery  
Zone Artisanale de Pré-Mairy  
74370 PRINGY-FRANCE

**Distributed by:** **ALLERGAN**  
Australia Pty Ltd  
GORDON NSW 2072



0459

#### COMPOSITION

Cross-linked hyaluronic acid 24 mg  
Phosphate buffer pH 7.2 q.s. 1 ml  
One syringe contains 0.8 ml of **Juvéderm ULTRA PLUS™** injectable gel.  
Moist heat sterilised.

#### DESCRIPTION

**Juvéderm ULTRA PLUS™** injectable gel is a sterile pyrogen-free physiological solution of cross-linked hyaluronic acid which is not of animal origin.  
The gel is presented in a graduated, pre-filled and disposable syringe. Each box contains 2 syringes of **Juvéderm ULTRA PLUS™** injectable gel, 4 27G1/2" - disposable sterile needles reserved for injection of **Juvéderm ULTRA PLUS™** injectable gel, a product leaflet and a set of labels showing the batch number, one of which should be attached to the patient's file and the other should be given to the patient in order to ensure traceability.

#### INDICATIONS

**Juvéderm ULTRA PLUS™** injectable gel is an injectable implant indicated for use in the filling of medium size and deep wrinkles of the face by injection into the mid and/or deep dermis and to increase the volume of the lips.

#### CONTRA-INDICATIONS

- Do not inject **Juvéderm ULTRA PLUS™** injectable gel into the eye contours (crow's feet, eyelids and glabellar region).
- The application of the **Juvéderm ULTRA PLUS™** in the bags under the eyes is reserved to specialists specifically trained in this technique and having a sound knowledge of the physiology for this particular area.
- Do not overcorrect.
- Juvéderm ULTRA PLUS™** injectable gel must not be used in patients who are known to be hypersensitive to hyaluronic acid.
- Juvéderm ULTRA PLUS™** injectable gel is contraindicated for patients with severe allergies manifested by a history of anaphylaxis or history of presence of multiple severe allergies.
- Juvéderm ULTRA PLUS™** injectable gel contains trace amounts of gram positive bacterial proteins and is contraindicated for patients with a history of allergies to such material.
- Juvéderm ULTRA PLUS™** injectable gel must not be used simultaneously with laser therapy, chemical peeling or dermabrasion.

#### PRECAUTIONS FOR USE

- Juvéderm ULTRA PLUS™** injectable gel is not indicated for injections other than intradermal injections.
- There is no available clinical data (efficiency, tolerance) about injection of **Juvéderm ULTRA PLUS™** injectable gel into an area which has already been treated with another filling product.
- There is no available clinical data (efficiency, tolerance) about injection of **Juvéderm ULTRA PLUS™** injectable gel in patients with a past history or a declared autoimmune disease. The practitioner should then decide to inject case by case, according to the nature of the disease and the associated treatment and ensure a particular follow-up of these patients.
- The safety of **Juvéderm ULTRA PLUS™** injectable gel for use during pregnancy, in breastfeeding females or in patients under 18 years has not been established.
- The safety of **Juvéderm ULTRA PLUS™** injectable gel in patients with increased susceptibility to keloid formation and hypertrophic scarring is unknown.
- Patients should be recommended not to apply make-up for 12 hours after the injection and to avoid prolonged exposure to sunlight, UV light, freezing temperatures or using saunas or Turkish baths for the two weeks after the injection.
- If the needle is blocked, do not increase the pressure on the plunger rod but stop the injection and replace the needle.

#### INCOMPATIBILITIES

Hyaluronic acid is known to be incompatible with quaternary ammonium salts such as benzalkonium chloride. **Juvéderm ULTRA PLUS™** injectable gel should never therefore be placed in contact with these substances or with medical-surgical instrumentation which has been treated with this type of substance.

#### UNDESIRABLE EFFECTS

Practitioners must inform the patient that there are potential side effects associated with implantation of this device, which may occur immediately or may be delayed. These include (non-exhaustive list) :

- Inflammatory reactions (e.g. redness, oedema, erythema) which may be associated with itching, pain on pressure, occurring after the injection. These reactions may last for a week.
- Induration or nodules at the injection site.
- Discoloration of the injection site.
- Poor effect or weak filling effect.
- Cases of glabellar necrosis, abscess formation, granuloma and hypersensitivity have all been reported in the literature following hyaluronic acid injection. It is therefore important to take such possible complications into account.

Patients must report inflammatory reactions which persist for more than one week or any other secondary effect which develops, to their practitioner as soon as possible. The practitioner should treat these as appropriate.

Any other undesirable side effects associated with injection of **Juvéderm ULTRA PLUS™** injectable gel must be reported to the distributor.

#### METHOD OF USE - POSOLOGY

This device is designed to be injected into the dermis by a practitioner. The technique used for this is essential in the success of treatment and this device must therefore be used by doctors who have received specific training in the injection technique for filling wrinkles.

- Before starting treatment patients should be informed of the indications for the device, its contra-indications, incompatibilities and potential undesirable effects.
- The area to be treated should be disinfected thoroughly prior to the injection.
- Remove tip cap by pulling it straight off the syringe as shown in fig. 1. Then firmly push the needle provided in the box (fig. 2) into the syringe, screwing it gently clockwise. Twist once more until it is fully locked and has the needle cap in the position shown in fig. 3. If the needle cap is positioned as shown in fig. 4, it is incorrectly attached. Next, remove the protective cap by holding the body of the syringe in one hand, the protective cap in the other, as shown in fig. 5, and pulling the two hands in opposite directions. Failure to comply with these precautions could cause a disengagement of the needle and/or product leakage at luer-lock level.
- Inject slowly into the dermis using the linear tracking injection technique using the 27G1/2" needle provided. The amount injected will depend on the wrinkles which are to be corrected.
- It is important to massage the area treated after the injection in order to ensure that the substance has been uniformly distributed.

#### WARNINGS

- Do not inject **Juvéderm ULTRA PLUS™** injectable gel into the blood vessels (intravascular).
- **Juvéderm ULTRA PLUS™** injectable gel must not be used in areas presenting cutaneous inflammatory and/or infectious processes (e.g. acne).
- For surface peels, it is recommended, not to inject **Juvéderm ULTRA PLUS™** injectable gel if the inflammatory reaction generated is significant.
- Confirm the integrity of the sterility protector before use.
- Do not re-use.
- Do not re-sterilise.
- The needle used must be disposed of in a special receptacle.

#### STORAGE CONDITIONS AND SHELF LIFE

- Store between 2°C and 25°C.
- Avoid freezing or heat.
- Avoid exposure to light.
- Avoid knocks.
- **Juvéderm ULTRA PLUS™** injectable gel must be used prior to the expiration date printed on the package. **Juvéderm ULTRA PLUS™** injectable gel has a shelf life of 24 months when stored between 2°C and 25°C.

**Juvéderm ULTRA PLUS™** injectable gel contains trace amounts (<2ppm) of the cross linking agent butanediol diglycidyl ether (BDDE).

#### POISON SCHEDULES

S4 in all Australian states.



- Does not contain latex



- Do not re-use



- Attention; see instructions for use



- Do not use if the packaging is damaged



- Temperature limit



- Fragile



- Store away from light



- Batch No.



- Use by



- Reference



- Syringe.



- Needle



- Sterile, sterilised by moist heat



- Sterile, sterilised by radiation.